



COOL/ EFFICIENT CUTTING SYSTEM

INTRODUCING A CUTTER HEAD THAT HELPS COOL YOUR MACHINE

Shinn Systems introduces the revolutionary SKC-Series of cutter heads that incorporates a built in oil cooler to reduce hydraulic temperature! Not only is the SKC-Series the first skid steer mounted head with integrated oil cooling, it is also the most efficient head on the market

- Performance**-The SKC-60 utilizes the most effective cutting teeth available. On skid steer powered units this is critical since you want to make the most of the limited power you have available. Slice through wood instead of pounding it with hammers or blunt faced carbide. High torque means higher production-faster cutter recovery times.
- Integrated Cooler**-Using the airflow produced in the cutter head, air is drawn through a built in cooler that cools the oil before it is sent back into the machine, reducing operating temperatures and down time.
- Heavy Duty Construction**-The shield and belt covers are made of 1/2" AR 400 plate, while the enplates are 1/2" AR 400 steel. In the tradition of all Shinn Systems products, the SKC-Series is over-built to last in a harsh environment.

FINALLY, A CUTTER HEAD THAT HELPS YOU KEEP YOUR COOL-THE SKC-60

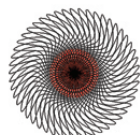

Optional Integrated Oil Cooling-How It Works

The patented cutter head design utilizes slots located just behind deflector baffles. As air and debris flow through the cutter head, the deflector baffles redirect material and air downward into the teeth. This results in finer chips. This also causes a low pressure area to develop just aft of the baffle. This draws airflow in from the upper compartment through the slots, while keeping debris out. Since the upper portion of the cutter head is sealed, this in turn, draws up to 500 cubic feet per minute of outside air through the oil cooler! The cooled oil is then sent back to the machine.

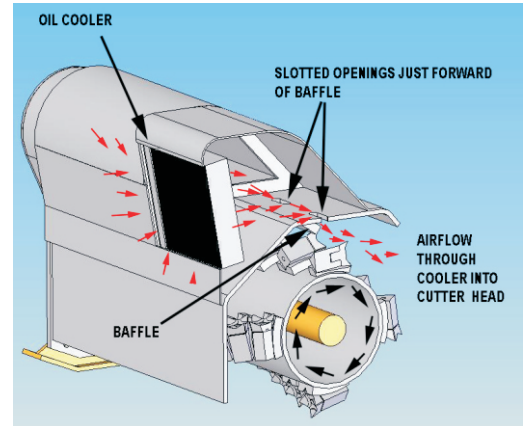

Extreme Efficiency Teeth

Sharp, high strength teeth slice through the toughest wood. 4 cutting tips means that you can rotate the teeth up to 4 times. Low Cost-under \$22.00 each.

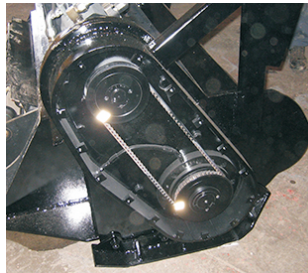

Gates PolyChain GT2-

Long life, heavy duty Kevlar strand belt drive. Rated to 300 HP.



Hydraulic Cooler-Equipped with

removable debris screen. Located within easy sight of the operator

Specifications

	SKC-48	SKC-60
Overall width	1575 mm (62 in)	1800 mm (71 in)
Working width	1210 mm (48 in)	1520 mm (60 in)
Length	1520 mm (48 in)	1520 mm (60 in)
Overall height	1450 mm (57 in)	1450 mm (57 in)
Weight	2050 lbs	2250 lbs
Drive Method	Gates PolyChain Belt	(2) Gates PolyChain Belt
Motor	Axial Piston Hydraulic	(2) Axial Piston Hydraulic
Drum Speed Range	1800-2100 RPM	1800-2100 RPM
Optimum hydraulic flow	102-170 L/min (27+ GPM)	102-170 L/min (27+ GPM)

Note: The product depicted in this literature is protect by one or more U.S. Patents. Other patents pending.

SHINN SYSTEMS, INC
NORTH AMERICA
 1321 Upland Drive
 Suite 77043
 Houston TX, 7553
 (704) 597-2005
 (704) 791-6259

IMPORTANT: Shinn Systems reserves the right to change these specifications without notice and without incurring any obligation pertaining to such change. Shinn Systems does not warrant the safety or reliability of components from other manufacturers.



SHINN SYSTEMS™

Visit Shinn Systems on the Web at
<http://www.shinnsystems.com>
 Printed in U.S.A.

©2022 SHINN SYSTEMS, INC.
 All Rights Reserved.